

180 Challenger* 180 Challenger* SE



technical specifications

DIMENSIONS

Overall length	17' 7" (5.36m)
Beam	8' 2" (2.49m)
Draft	12" (30.5cm)
Weight (dry) [180 SE]	1,968 lbs (893kg)
Weight (dry) [180]	1,913 lbs (868kg)
Storage capacity	23 cu ft (0.65cu m)
Seating capacity	8
Weight capacity	1,440 lbs (653kg)
Fuel capacity	28 US gal (105L)
Oil capacity	0.92 US gal (3.5L)

DIMENSIONS (ON TRAILER)

Length [§]	18' 8" (5.68m)
Width	8' 2" (2.49m)
Height (no tower)	6' 5" (1.95m)
Height (tower down) [180 SE]	6' 7" (2m)
Height (tower up) [180 SE]	8' 5" (2.57m)
Gross weight [180 SE]	2,898 lbs (1,315kg)
[180]	2,843 lbs (1,290kg)

ENGINE

Model	4-TEC® 1503
Displacement	1,494cc
Horsepower	215 hp
Type	4-stroke
Cylinders	3
Max RPM	8,000

DRIVE UNIT

Axial flow	Single-stage
Impeller	Stainless steel
Pump diameter	6 1/4" (15.63cm)

ELECTRICAL

Generator	30 amp/380W
Battery	12V

HULL AND DECK

Material	Composite FRP
Deadrise	20°
Colors	Gold or Steel Blue

[§]With swing-away tongue folded

ADDITIONAL SAFETY & CONVENIENCE FEATURES

- Digital Information Center w/18 functions including compass, water temperature, hour meter
- Satellite-ready AM/FM/CD stereo w/MP3 port and 2 speakers
- Track and swivel driver/passenger seats
- Huge passenger space
- Driver/passenger console
- Glove compartment
- 12 volt jack
- Chrome cleats (6)
- Stainless steel eyes bow and stern
- Non-slip grab handles (8)
- Navigational lights
- Horn (flush mount)
- Tow eye
- D.E.S.S.
- Safety lanyard
- RPM limiter
- Non-skid decking
- Auto bilge pump/switch
- Operator's guide
- Limited warranty
- Boat cover (opt.)

- SE Package -

- Snap-in carpet
- Stereo remote
- Backlit depth sounder
- Bimini top
- Wakeboard tower (opt.)

TRAILER

- Single axle with disc brakes
- Swing-away tongue
- Galvanized (opt.)

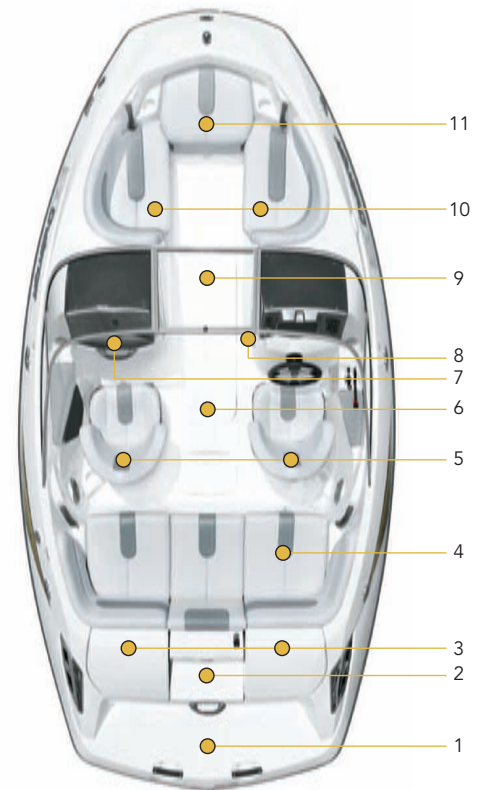

1. Swim platform w/2-step ladder
2. Walk-through to swim platform
3. Dual-access rear storage
4. Removable cooler under rear seat
5. Track and swivel driver and passenger seats
6. Large in-floor ski storage
7. Satellite-ready AM/FM/CD stereo w/MP3 port
8. Cockpit courtesy lights
9. Full, wraparound glass windshield
10. Abundant on-board storage
11. Bow filler cushion creates lounge area

